

3D

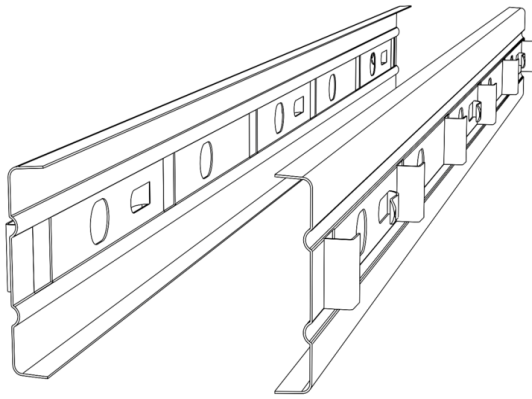

A-A

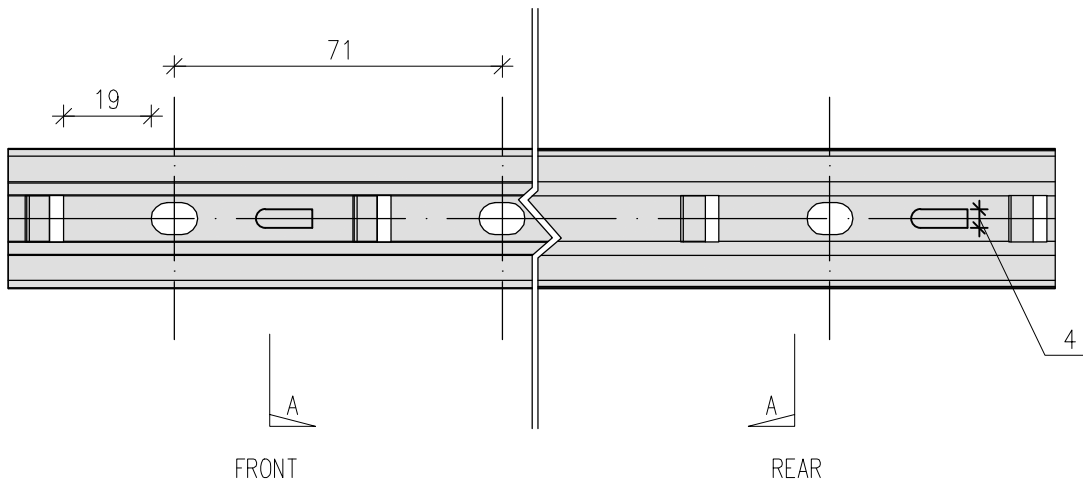
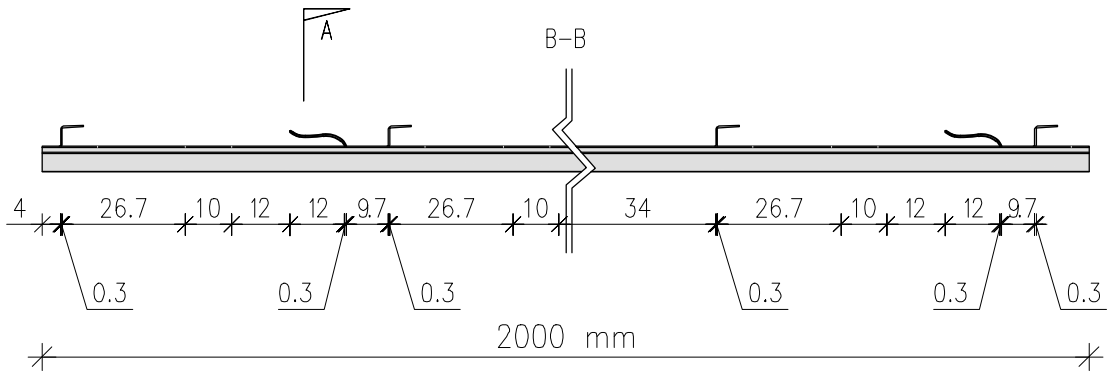
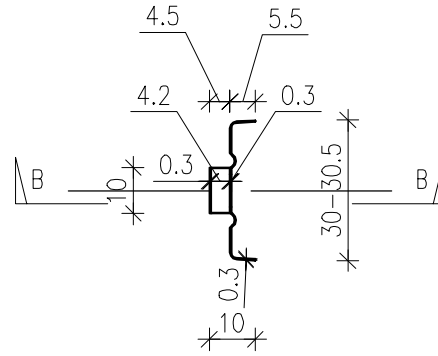

FRONT

REAR

INFO:

Highest fire resistance class A1.
 Manufacturer's warranty 20 years.
 Made of galvanized or stainless steel.
 Completely resistant to atmospheric conditions,
 including UV rays.
 Length 200 to 2280 mm.
 Weight 0,17 kg/m.
 Available DryTherm SEMS-KD option.
 Same profile for all panel series.

NOTS:

STRAMA PANELS

author:	
ENG. MARTA GAC	
contact:	
tel.: +48 504 265 748 e-mail: biuro@stramagroup.com	
title:	
Mounting strip STRAMA PANELS SEMS-LM140	
date:	version:
29.04.2021	1.1
scale:	page:
NONE	1/1