

3D

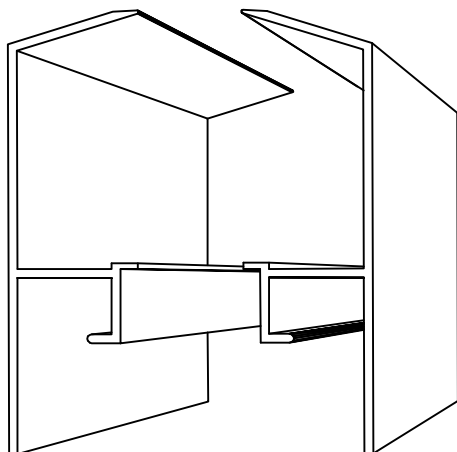

A-A

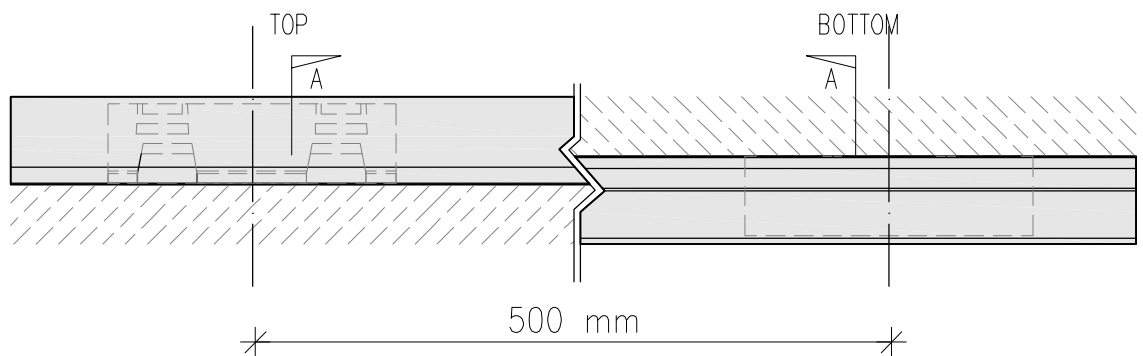
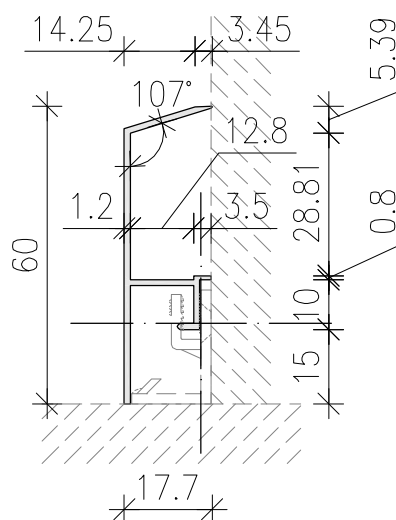

500 mm

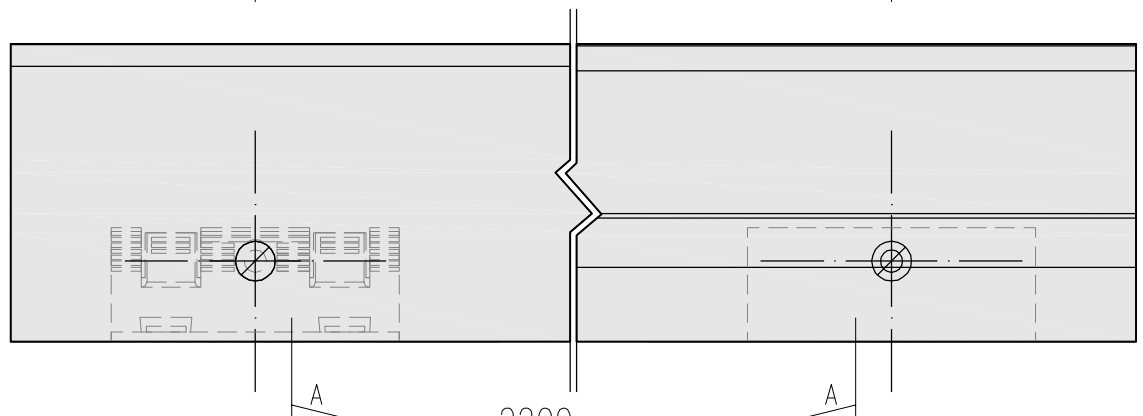

2200 mm

\*on request, any length up to 6700 mm

FRONT

REAR

**INFO:**

Highest fire resistance class A1.  
 Manufacturer's warranty 5 years.  
 Total cladding thickness only 18 mm.  
 Made of anodised aluminum available in six colors.  
 Available RAL Color powder coating, and WOOD & COLOUR DESIGN high-performance laminating films.  
 Completely resistant to atmospheric conditions, including UV rays.  
 Panel length 2200 mm.  
 Panel width 60 mm.  
 Weight 0.33 kg/m

**NOTS:**

**STRAMA PANELS**

<b>author:</b>	
ENG. ARCHITECT DAMIAN ZAREMBA	
<b>contact:</b>	
tel.: +48 22 751 66 51	e-mail: biuro@stramagroup.com
<b>title:</b>	
SKIRTING BOARD STRAMA LP-Alu 60	
<b>date:</b>	<b>version:</b>
25.09.2019	1.2
<b>scale:</b>	<b>page:</b>
NONE	1/1