

3D

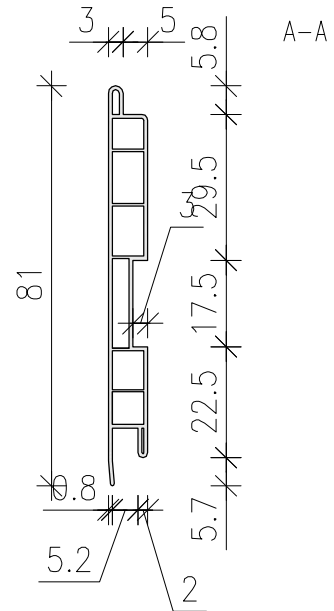

A-A

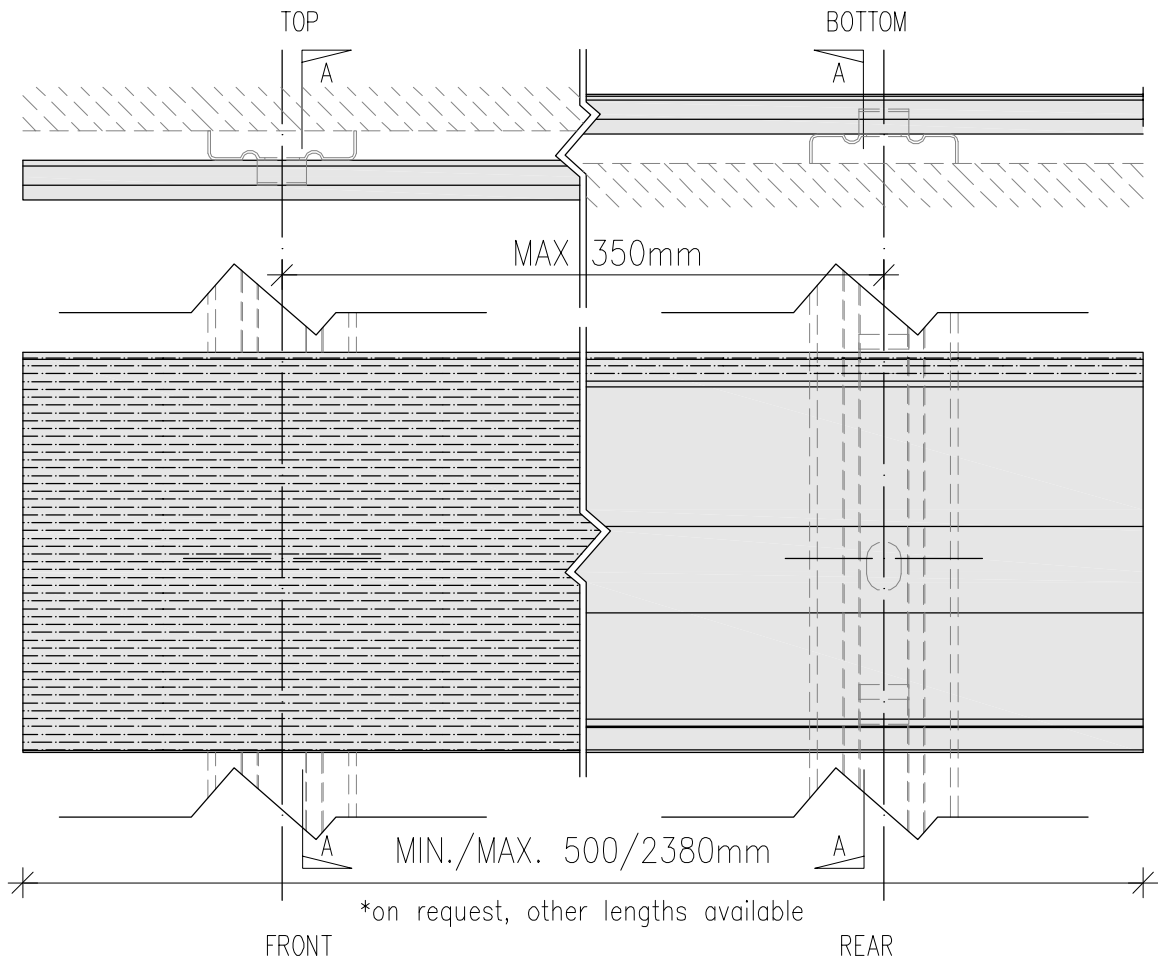

*on request, other lengths available

INFO:

Fire resistance class A2 (NRO).
 Manufacturer's warranty up to 15 years.
 Total cladding thickness only 16 mm.
 Made of PVC, laminated with Renolit EXOFOL
 multilayer foil of the MX, PX or FX series.
 Available in several hundred colors.
 High resistance to weather conditions,
 including UV rays.
 Panel length min/max 500/2380mm.
 Panel width nominal/coverage 81/71mm.
 Weight (including mounting strip) 4.15 kg/m².
 Available DryTherm SEMS-KD option.
 Can be used with other Strama panels.

NOTS:

STRAMA PANELS

author:	
ENG. ARCHITECT DAMIAN ZAREMBA	
contact:	
tel.: +48 22 751 66 51	e-mail: biuro@stramagroup.com
title:	
Facade panel STRAMA PANELS Wood&Colour Design SP-WCD	
date:	version:
25.09.2019	1.5
scale:	page:
NONE	1/1