

3D

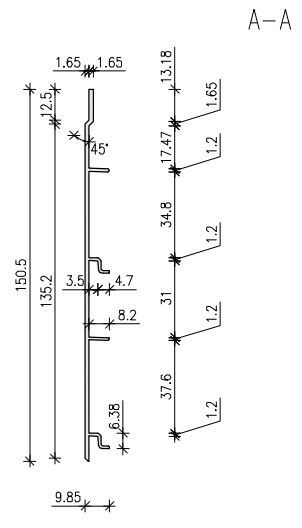

A-A

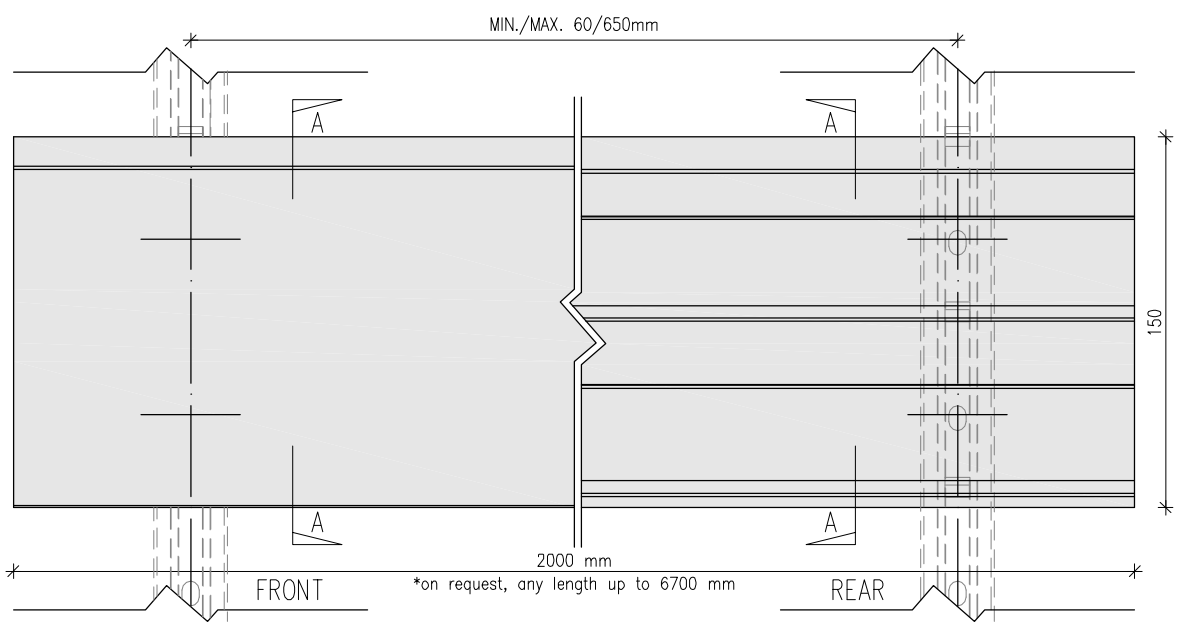
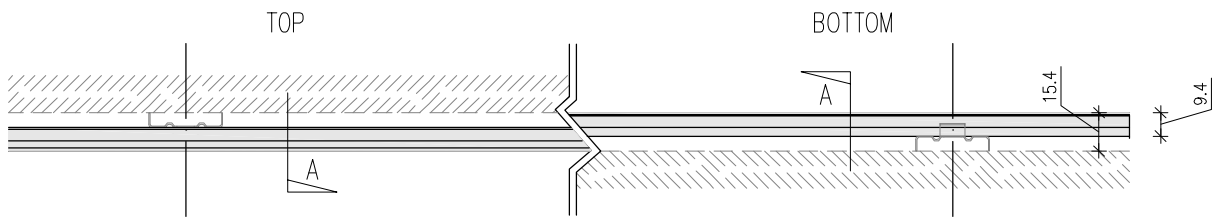

*on request, any length up to 6700 mm

INFO: Highest fire resistance class A1.
 Manufacturer's warranty 20 years.
 Total cladding thickness only 17 mm.
 Made of anodised aluminum available in six colors.
 Available RAL Color powder coating, and WOOD & COLOUR DESIGN high-performance laminating films.
 Completely resistant to atmospheric conditions, including UV rays.
 Panel length normal/max 2000/6700 mm.
 Panel width nominal/coverage 151/142 mm.
 Dilation 2-3mm/m.
 Weight (including mounting strip) 6.10 kg/m²
 Available DryTherm SEMS-KD option.
 Can be combined with other series of Strama panels.

NOTS:

 STRAMA PANELS	
author: ENG. ARCHITECT DAMIAN ZAREMBA	
contact: tel.: +48 22 751 66 51 e-mail: biuro@stramagroup.com	
title: Anodised aluminum facade STRAMA PANELS Alu Design SP-AD panel	
date: 12.12.2019	version: 2.1
scale: NONE	page: 1/1